

PARTS

Main

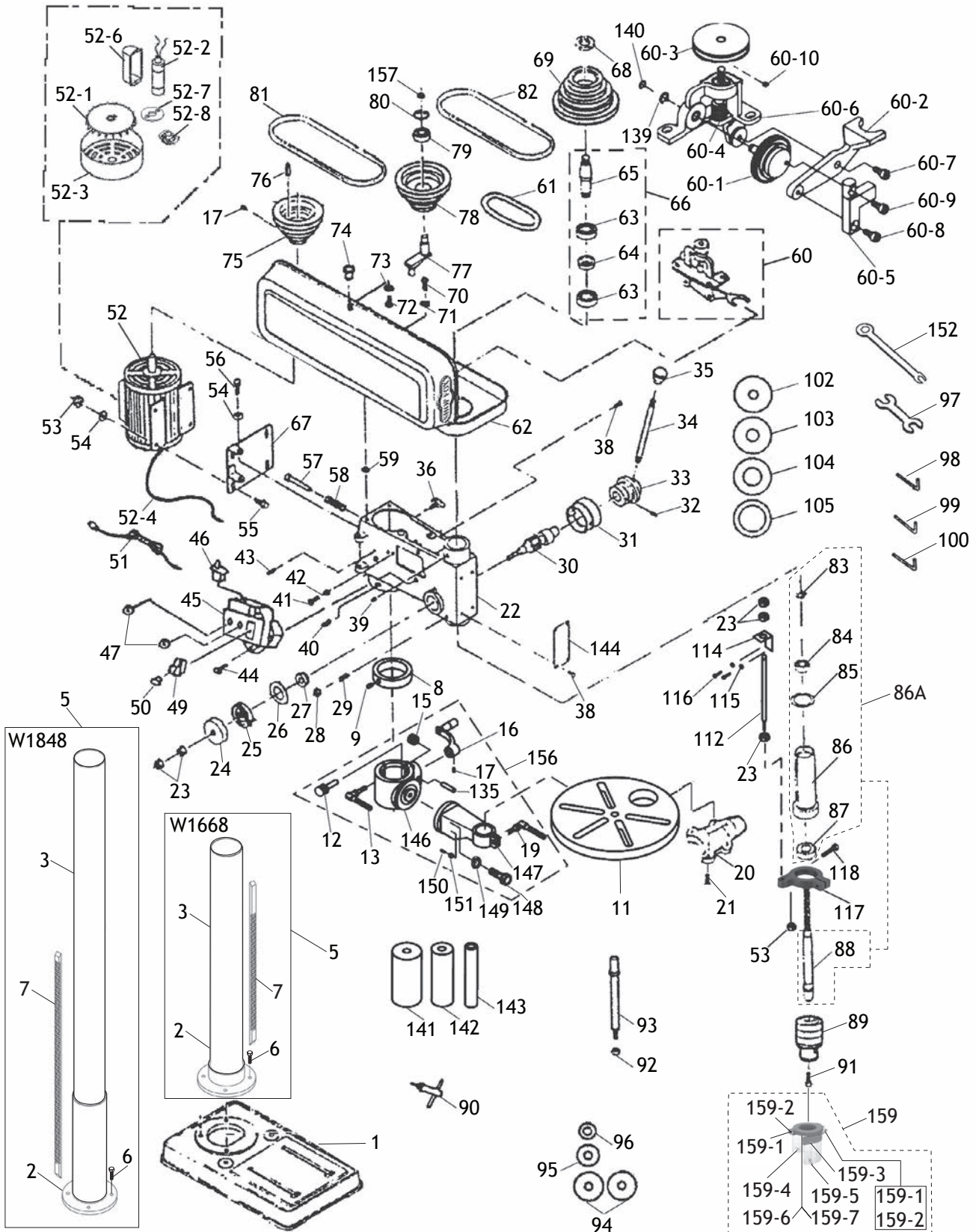

Main Parts List

REF	PART #	DESCRIPTION
1	X1848001	BASE (W1848)
1	X1668001	BASE (W1668)
2	X1848002	COLUMN FLANGE (W1848)
2	X1668002	COLUMN FLANGE (W1668)
3	X1848003	COLUMN (W1848)
3	X1668003	COLUMN (W1668)
5	X1848005	COLUMN & COLUMN FLANGE ASSY (W1848)
5	X1668005	COLUMN & COLUMN FLANGE ASSY (W1668)
6	X1848006	HEX BOLT M10-1.5 X 35 (W1848)
6	X1668006	HEX BOLT M10-1.5 X 25 (W1668)
7	X1848007	RACK 31-1/2" (W1848)
7	X1668007	RACK 16-15/16 (W1668)
8	X1848008	COLUMN RING
9	X1848009	SET SCREW M6-1 X 10
11	X1848011	TABLE
12	X1848012	WORM PINION
13	X1848013	CLAMP BOLT M12-1.75 X 50
15	X1848015	WORM GEAR
16	X1848016	LIFT HANDLE
17	X1848017	SET SCREW M6-1 X 10
19	X1848019	CLAMP BOLT M10-1.5 X 30
20	X1848020	DUST PORT 2"
21	X1848021	PHLP HD SCR M4-.7 X 22
22	X1848022	HEAD CASTING
23	X1848023	HEX NUT M10-1.5
24	X1848024	SPRING COVER
25	X1848025	RETURN SPRING
26	X1848026	SPRING WASHER 10MM
27	X1848027	BUSHING
28	X1848028	HEX NUT M8-1.25
29	X1848029	SET SCREW M8-1.25 X 25 DOG-PT
30	X1848030	FEED SHAFT
31	X1848031	DEPTH COLLAR
32	X1848032	ROLL PIN 6 X 20MM
33	X1848033	FEED COLLAR
34	X1848034	HANDLE BAR M10-1.5, 155L
35	X1848035	KNOB M10-1.5
36	X1848036	LOCK KNOB M8-1.25
38	X1848038	RIVET
39	X1848039	SET SCREW M8-1.25 X 10
40	X1848040	SET SCREW M10-1.5 X 12
41	X1848041	PHLP HD SCR M4-.7 X 10
42	X1848042	EXT TOOTH WASHER 4MM
43	X1848043	ROLL PIN 6 X 20MM
44	X1848044	PHLP HD SCR M4-.7 X 10
45	X1848045	SWITCH BOX
46	X1848046	LIMIT SWITCH
47	X1848047	STRAIN RELIEF THREADED
49	X1848049	SHOP FOX PADDLE SWITCH 110V
50	X1848050	PADDLE SWITCH KEY
51	X1848051	POWER CORD 18G 3W 112" 5-15P
52	X1848052	MOTOR 3/4HP 110V 1-PH
52-1	X1848052-1	MOTOR FAN

REF	PART #	DESCRIPTION
52-2	X1848052-2	S. CAPACITOR 200M 125V
52-3	X1848052-3	MOTOR FAN COVER
52-4	X1848052-4	WIRING HARNESS
52-6	X1848052-6	CAPACITOR COVER
52-7	X1848052-7	CENTRIFUGAL SWITCH
52-8	X1848052-8	CONTACT PLATE
53	X1848053	HEX NUT M8-1.25
54	X1848054	FLAT WASHER 8MM
55	X1848055	HEX BOLT M8-1.25 X 25
56	X1848056	HEX BOLT M8-1.25 X 20
57	X1848057	PUSH ROD
58	X1848058	SPRING
59	X1848059	RUBBER WASHER
60	X1848060	OSCILLATING MECHANISM
60-1	X1848060-1	PLASTIC GEAR
60-2	X1848060-2	OSCILLATING MECHANISM ARM
60-3	X1848060-3	PULLEY
60-4	X1848060-4	WORM GEAR
60-5	X1848060-5	DRIVE ARM
60-6	X1848060-6	BODY
60-7	X1848060-7	OSC. MECH ARM BOLT M6-1 X 20
60-8	X1848060-8	CAP SCREW M5-.8 X 15
60-9	X1848060-9	CAP SCREW M5-.8 X 15
60-10	X1848060-10	SET SCREW M6-1 X 6
61	X1848061	OSCILLATOR BELT
62	X1848062	PULLEY COVER
63	X1848063	BALL BEARING 6203-2RS
64	X1848064	COLLAR
65	X1848065	INTERNAL SPLINE SLEEVE
66	X1848066	SPLINE SLEEVE ASSY
67	X1848067	MOTOR MOUNT
68	X1848068	LOCK NUT M18-1.5
69	X1848069	SPINDLE PULLEY
70	X1848070	PHLP HD SCR M6-1.0 X 20
71	X1848071	LOCK WASHER 6MM
72	X1848072	PHLP HD SCR M5-0.8 X 10
73	X1848073	FLAT WASHER 5MM
74	X1848074	KNOB
75	X1848075	MOTOR PULLEY
76	X1848076	KEY
77	X1848077	IDLER ARM
78	X1848078	IDLER PULLEY
79	X1848079	BALL BEARING 6202-2RS
80	X1848080	INT RETAINING RING 35MM
81	X1848081	V-BELT M20 3L200
82	X1848082	V-BELT M26 3L260
83	X1848083	EXT RETAINING RING 11MM
84	X1848084	BALL BEARING 6201-2RS
85	X1848085	RUBBER WASHER
86	X1848086	QUILL
86A	X1848086A	QUILL ASSY
87	X1848087	BALL BEARING 6202ZZ

Main Parts List (Cont.)

REF	PART #	DESCRIPTION
88	X1848088	SPINDLE, JT33 CHUCK
89	X1848089	CHUCK 1-16MM JT33
90	X1848090	CHUCK KEY
91	X1848091	CAP SCREW M5-0.8 X 20
92	X1848092	HEX NUT M8-1.25
93	X1848093	MANDREL
94	X1848094	MANDREL WASHER 1-3/4"
95	X1848095	MANDREL WASHER 7/8"
96	X1848096	MANDREL WASHER 5/8"
97	X1848097	WRENCH 14MM X 1/2"
98	X1848098	3MM HEX WRENCH
99	X1848099	4MM HEX WRENCH
100	X1848100	5MM HEX WRENCH
102	X1848102	TABLE INSERT 5/8" I.D.
103	X1848103	TABLE INSERT 1" I.D.
104	X1848104	TABLE INSERT 1 3/8" I.D.
105	X1848105	TABLE INSERT 1 7/8" I.D.
112	X1848112	DEPTH STOP ROD
114	X1848114	DEPTH STOP BRACKET
115	X1848115	FLAT WASHER 5MM
116	X1848116	CAP SCREW M5-0.8 X 12
117	X1848117	DEPTH STOP MOUNT
118	X1848118	CAP SCREW M8-1.25 X 20
135	X1848135	AXLE

REF	PART #	DESCRIPTION
139	X1848139	FLAT WASHER 8MM
140	X1848140	EXT RETAINING RING 8MM
141	X1848141	RUBBER DRUM 2" X 4-1/4"
142	X1848142	RUBBER DRUM 1-1/2" X 4-1/4"
143	X1848143	RUBBER DRUM 1" X 4-1/4"
144	X1848144	TRAVEL INDICATOR PLATE
146	X1848146	TABLE BRACKET N/S
147	X1848147	COLUMN SUPPORT N/S
148	X1848148	HEX BOLT M16-2 X 50
149	X1848149	FLAT WASHER 16MM
150	X1848150	COLUMN SUPPORT PIN
151	X1848151	HEX NUT M6-1
152	X1848152	OSCILLATING DRILL PRESS WRENCH
156	X1848156	TABLE BRACKET ASSY
157	X1848157	EXT RETAINING RING 15MM
159	X1848159	CHUCK GUARD ASSY
159-1	X1848159-1	PHLP HD SCR M4-.7 X 30
159-2	X1848159-2	HEX NUT M4-.7
159-3	X1848159-3	TAP SCREW M2.2 X 4.5
159-4	X1848159-4	HEX BOLT M5-.8 X 12
159-5	X1848159-5	WING NUT M5-.8
159-6	X1848159-6	PHLP HD SCR M4-.7 X 10
159-7	X1848159-7	FLAT WASHER 4MM

Labels

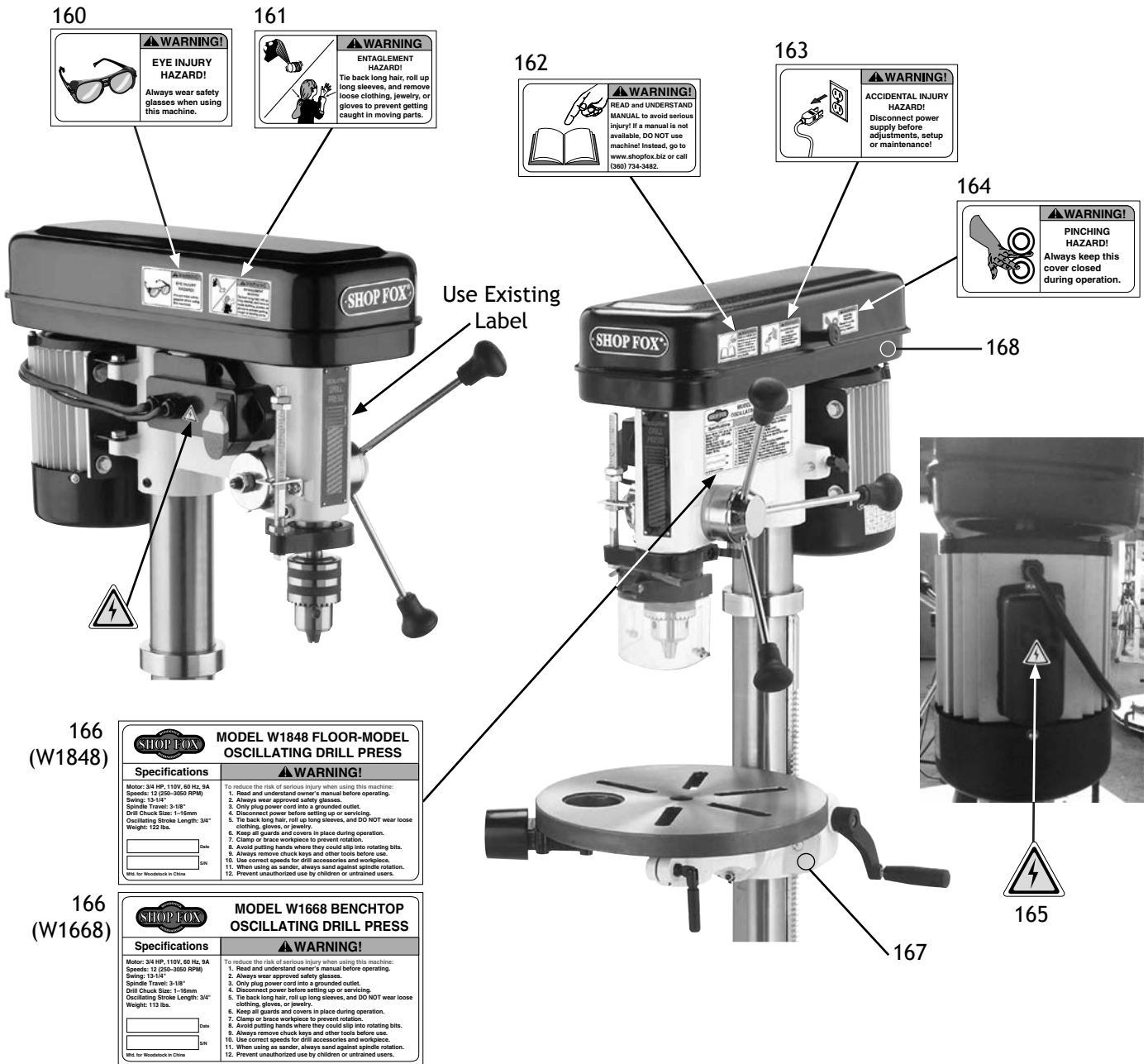

160

WARNING!
EYE INJURY HAZARD!
Always wear safety glasses when using this machine.

161

WARNING!
ENTANGLEMENT HAZARD!
Tie back long hair, roll up long sleeves, and remove loose clothing, jewelry, or gloves to prevent getting caught in moving parts.

162

WARNING!
READ and UNDERSTAND MANUAL! To avoid serious injury! If a manual is not available, DO NOT use machine! Instead, go to www.shopfox.biz or call (360) 734-3482.

163

WARNING!
ACCIDENTAL INJURY HAZARD!
Disconnect power supply before adjustments, setup or maintenance!

164

WARNING!
PINCHING HAZARD!
Always keep this cover closed during operation.

166 (W1848)

SHOP FOX MODEL W1848 FLOOR-MODEL OSCILLATING DRILL PRESS

Specifications

WARNING!

To reduce the risk of serious injury when using this machine:

1. Read and understand owner's manual before operating.
2. Always wear approved safety glasses.
3. Only plug power cord into a grounded outlet.
4. Disconnect power before setting up or servicing.
5. Tie back long hair, roll up long sleeves, and DO NOT wear loose clothing, gloves, or jewelry.
6. Keep all guards and covers in place during operation.
7. Clamp or brace workpiece to prevent rotation.
8. Avoid putting hands where they could slip into rotating bits.
9. Always remove chuck keys and other tools before use.
10. Use correct speeds for drill accessories and workpiece.
11. When using as sander, always sand against spindle rotation.
12. Prevent unauthorized use by children or untrained users.

Motor: 3/4 HP, 110V, 60 Hz, 5A
Speeds: 12 (250-3650 RPM)
Swing: 15-1/4"
Spindle Travel: 3-1/8"
Drill Chuck Size: 1-1/8mm
Oscillating Stroke Length: 3/4"
Weight: 122 lbs.

MADE IN CHINA

166 (W1668)

SHOP FOX MODEL W1668 BENCHTOP OSCILLATING DRILL PRESS

Specifications

WARNING!

To reduce the risk of serious injury when using this machine:

1. Read and understand owner's manual before operating.
2. Always wear approved safety glasses.
3. Only plug power cord into a grounded outlet.
4. Disconnect power before setting up or servicing.
5. Tie back long hair, roll up long sleeves, and DO NOT wear loose clothing, gloves, or jewelry.
6. Keep all guards and covers in place during operation.
7. Clamp or brace workpiece to prevent rotation.
8. Avoid putting hands where they could slip into rotating bits.
9. Always remove chuck keys and other tools before use.
10. Use correct speeds for drill accessories and workpiece.
11. When using as sander, always sand against spindle rotation.
12. Prevent unauthorized use by children or untrained users.

Motor: 3/4 HP, 110V, 60 Hz, 5A
Speeds: 12 (250-3650 RPM)
Swing: 15-1/4"
Spindle Travel: 3-1/8"
Drill Chuck Size: 1-1/8mm
Oscillating Stroke Length: 3/4"
Weight: 113 lbs.

MADE IN CHINA

MAINTENANCE

REF	PART #	DESCRIPTION
160	X1848160	EYE INJURY HAZARD LABEL
161	X1848161	ENTANGLEMENT HAZARD LABEL
162	X1848162	READ MANUAL LABEL
163	X1848163	DISCONNECT POWER LABEL
164	X1848164	PINCHING HAZARD LABEL

REF	PART #	DESCRIPTION
165	X1848165	ELECTRICITY LABEL
166	X1848166	MACHINE ID LABEL (W1848)
166	X1668166	MACHINE ID LABEL (W1668)
167	X1848167	TOUCH-UP PAINT, SHOP FOX WHITE
168	X1848168	TOUCH-UP PAINT, SHOP FOX BLACK